

# Gimleo

Catalog General

Global professional heat exchanger manufacturer



High Efficiency Tube In Shell Heat Exchangers

Titanium Heat Exchangers

Coaxial Heat Exchangers



FOSHAN SHUNDE GIMLEO HEAT EXCHANGER CO., LTD

Address: Building 12th, zhongjizhigu, No.15 Shunye West Road, Xingtan, Shunde, Foshan, Guangdong, China

P.C:528325 Fax:+86-757-2837 8561

Tel:+86-757-2837-8560 Web:www.gimleo.com

Email:sales@gimleo.com



All contents in this catalog are for reference only. All final products are subject to the production drawings provided by the sales manager.

FOSHAN SHUNDE GIMLEO HEAT EXCHANGER CO., LTD

## Company Profile

Founded in 2005, Gimleo Heat Exchanger Co.,Ltd is a national high-tech enterprise specializing in the research, design, development and manufacturing of energy-saving heat exchangers. With our powerful heat exchanger engineering & technology innovation, Gimleo is dedicated to providing you with high quality heat exchanger solutions and unparalleled customer support, Our products are widely applied to commercial & residential air conditioners, chillers, air-source heat pumps, swimming pool heat pumps, aquarium heat pumps, quarium chillers and so on.

### Products

High efficiency tube in shell heat exchanger, Titanium tube heat exchanger, Co-axial heat exchanger, Shell and tube heat exchanger, PPR shell heat exchanger, Cupro-nickel heat exchanger, double wall heat exchanger.

### Facilities

Helium leak detect machine , Yaskawa weld robots, MES manufacturing tracking system, Heat exchanger testing lab, Extreme pressure testing lab, along with high-educated staff.

### Certificates

ISO9001, RoHS 2.0, REACH, CE and Patents

### Corporations

We have established tight corporation with 40 plus foreign clients all over the world , and at the same time we have been serving famous heat pump manufacturers like Midea, GREE, TCL, PHNIX for over 10 years.

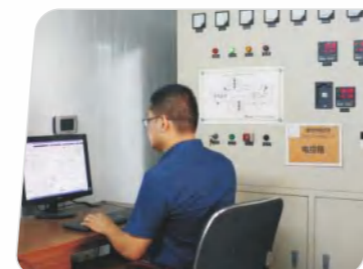

# CATA LOGUE

Foshan Shunde Gimleo Heat Exchanger Co., Ltd

Create blue sky and white clouds, enjoy lucid water  
and green mountains

**01 COMPANY PROFILE** ----- P01-P04

**02 PRODUCT INTRODUCTION** ----- P05-P12

**High Efficiency Tube in Shell Heat Exchangers** ----- P05-P19

1.1 Common Version Heat Exchanger

1.2 R series Heat Exchanger

1.3 Multi-tube Heat Exchanger

1.4 Large Heating Capacity Multi-tube Heat Exchanger

1.5 Enthalpy-adding Heat Exchanger

1.6 Double Wall Tube Heat Exchanger

**Titanium Heat Exchangers** ----- P13-P17

1.1 Common Version Titanium Heat Exchanger

1.2 Titanium Evaporator

1.3 PPR Titanium Heat Exchanger

**Coaxial Heat Exchangers** ----- P18-P19

**03 COOPERATIVE SERVICES** ----- P20-P22

# Company Strength

Top class technology International standard

Cutting edge technology, advanced design , details define the perfect product, we win our reputation with our qualified products.



MES system to control all procedure during manufacturing



Sophisticated helium leak testing machine



Highly effective office management system & highly educated professionals



Automated welding robots

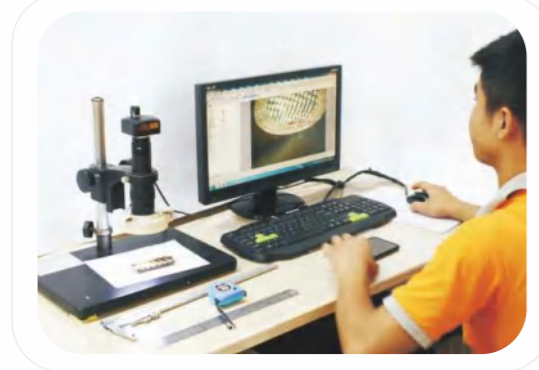

Strict quality control before shipment

**Gimleo**

## Corporate Honor



## Cooperation Enterprise

Gimleo leads the China heat exchanger market and has long-term cooperative relations with many well-known enterprises in China, such as Midea, GREE, TCL, Changhong, Solareast, Amitime, PHNIX etc.



In 2008, we began to enter the international market and exported to more than 40 countries, It has long-term cooperation with many enterprises, such as Rheem, HAYWARD, Dantherm, EMERSON, Temperzone, WATERCO etc.



# High Efficiency Tube In Shell Heat Exchangers

Global Professional Heat Exchanger Manufacturer With Over 18 Years' Engineering



## High Efficiency Tube In Shell Heat Exchanger Features And Naming Rules

### Product introduction

The tube in shell heat exchanger made of high-efficiency heat exchange coil has the advantages of high heat exchange efficiency, small volume and high safety. it could widely apply to air-sourced heat pump, ground source heat pump which are using water as coolant.

### Feature

- The overall copper tube has no internal welding point to ensure long-term stable operation of the system;
- After the copper tube is formed, it is installed into the shell to eliminate processing defects;
- There is no water flow blind zone in the water channel, the flow rate of the water channel is uniform, and the heat exchanger is not easy to freeze locally and scaling;
- The water inlet is located at the lowest point of the heat exchanger, which is convenient for drainage in low temperature season to prevent freezing.

### Material

#### Heat exchange tube

**Standard applied:** GB/T19447, or equal with ASTM B359, ASTM SB 359.

**Material:** Copper T2/TP2, and Nickel-Copper 90/10, Copper Bfe 10-1-1, Bfe 30-1-1 for option.

**Shell:** Carbon steel.

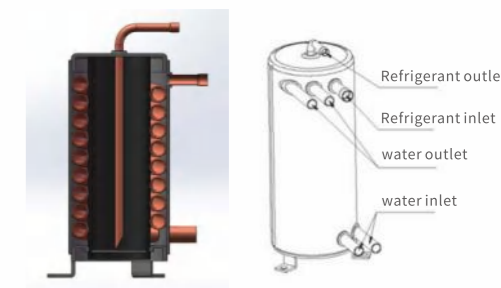

Type A with liquid receiver

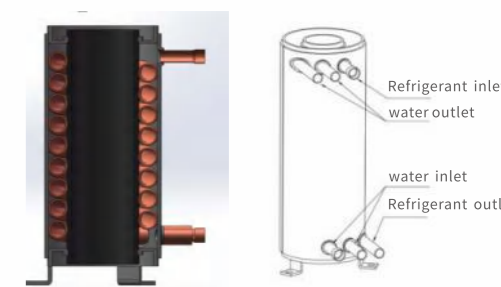

Type B without liquid receiver

### High Efficiency Tube In Shell Heat Exchanger Naming Rules

G/R X X X X X X X X

- Multi-connect type: x2 means two in a row, x4 means four in a row.
- F means product without connector, E means product with connector
- Inner surface type: M means inner screwed, G means smooth
- Tube material: C means copper, N means nickel-cupro
- Heating capacity: 1 means 1 hp, 15 means 15 hp
- D represents 15.88mm tube, H represents 19.05 mm tube, Q represents double wall, K represents 22mm tube, L represents 25.4mm tube, S represents 28mm tube
- D represents single 25.4mm tube, it is especially for one product
- A represents version with accumulator. B does not
- G represents regular version, R represents R series

### Common Version Heat Exchanger



#### Advantages and characteristics

- Use 19mm finned copper tubes for heat exchange.
- Safe and antifreeze.
- The heating and cooling capacity is balanced.



Type B

Type A

#### Technical data

Model	Heating capacity 1 kw	Heating capacity 2 kw	Cooling capacity kw	Water flow m <sup>3</sup> /h	Height mm
GAH01-CMF/GBH01-CMF	3.5	2.5	2.5	0.6	251
GAH02-CMF/GBH02-CMF	5	3.5	3.5	0.86	291
GAH03-CMF/GBH03-CMF	7	5	5	1.2	361
GAH04-CMF/GBH04-CMF	10	7.5	7.5	1.72	421
GAH05-CMF/GBH05-CMF	13	9.5	9.5	2.24	338
GAH06-CMF/GBH06-CMF	16	12	12	2.75	383
GAH07-CMF/GBH07-CMF	18	14	14	3.5	426
GAH08-CMF/GBH08-CMF	22	16	16	3.7	470
GAL10-CMF/GBL10-CMF	33	23	23	5.7	497
GAL12-CMF/GBL12-CMF	38	28	28	6.5	537
GAS15-CMF/GBS15-CMF	45	35	35	7.8	615

**Heating 1:** DB 7 °C, WB 6°C, Inlet water 40°C, Outlet water 45°C

**Heating 2:** DB -12°C, Outlet water 41°C

**Cooling:** DB 35 °C, WB 24°C, Inlet water 12°C, Outlet water 7°C

### R Series Heat Exchanger



#### Advantages and characteristics

- Use 19mm finned copper tubes for heat exchange.
- Low cost.
- Compact volume.
- Flow around structure, extreme heating efficient.



#### Technical data

Model	Heating capacity 1 kw	Heating capacity 2 kw	Cooling capacity kw	Water flow m <sup>3</sup> /h	Height mm
RAH02-CMF/RBH02-CMF	5	3.5	3	0.86	251
RAH03-CMF/RBH03-CMF	7	5	4	1.2	291
RAH04-CMF/RBH04-CMF	10	7.5	6.5	1.72	361
RAH05-CMF/RBH05-CMF	13	9.5	8.5	2.24	421
RAH06-CMF/RBH06-CMF	16	12	11	2.75	338
RAH07-CMF/RBH07-CMF	18	14	13	3.27	383
RAH08-CMF/RBH08-CMF	22	16	14	3.78	440
RAK05-CMF/RBK05-CMF	13	9.5	8.5	2.24	415
RAK06-CMF/RBK06-CMF	16	12	10	2.75	463

**Heating 1:** DB 7 °C, WB 6°C, Inlet water 40°C, Outlet water 45°C

**Heating 2:** DB -12°C, Outlet water 41°C

**Cooling:** DB 35 °C, WB 24°C, Inlet water 12°C, Outlet water 7°C

### Multi-tube Heat Exchanger



#### Advantages and characteristics

- Use 16mm finned copper tubes for heat exchange.
- Small water resistance.
- Low cost.
- Compact volume.
- Extreme cooling efficient.
- High heat exchange efficiency.



#### Technical data

Model	Heating capacity 1 kw	Heating capacity 2 kw	Cooling capacity kw	Water flow m <sup>3</sup> /h	Height mm
GAD01-CMF/GBD01-CMF	3	2	2	0.52	281
GAD1.5-CMF/GBD1.5-CMF	4.5	3	3	0.77	311
GAD03-CMF/GBD03-CMF	9	7.5	7.5	1.55	314
GAD04-CMF/GBD04-CMF	14	9.5	9.5	2.4	362
GAD05-CMF/GBD05-CMF	15.5	10.5	10.5	2.67	398
GAD06-CMF/GBD06-CMF	17	14	14.5	2.75	348
GAD07-CMF/GBD07-CMF	20	16.5	16.5	3.45	393
GAD08-CMF/GBD08-CMF	25	19	18.5	4.3	436
GAD10-CMF/GBD10-CMF	30	24	24	5.15	480
GAD12-CMF/GDL12-CMF	38	30	30	6.5	538

**Heating 1:** DB 7 °C, WB 6°C, Inlet water 40°C, Outlet water 45°C

**Heating 2:** DB -12°C, Outlet water 41°C

**Cooling:** DB 35 °C, WB 24°C, Inlet water 12°C, Outlet water 7°C

### Large Heating Capacity Multi-tube Heat Exchanger



#### Advantages and characteristics

- Use 22mm finned copper tubes for heat exchange.
- Small water resistance.
- Low cost.
- Compact volume.
- Extreme cooling efficient.
- High heat exchange efficiency.

#### Technical data

Model	Heating capacity 1 kw	Heating capacity 2 kw	Cooling capacity kw	Water flow m <sup>3</sup> /h	Height mm
GAK12-CMF-4	30	24	24	6.5	436
GAK15-CMF-4	40	32	30	7.8	456
GAK18-CMF-4	50	38	38	8.6	586
GAK25-CMF-4	85	70	70	14.5	586
GAK30-CMF-4	100	85	80	17	646

**Heating 1:** DB 7 °C, WB 6°C, Inlet water 40°C, Outlet water 45°C

**Heating 2:** DB -12°C, Outlet water 41°C

**Cooling:** DB 35 °C, WB 24°C, Inlet water 12°C, Outlet water 7°C

### Enthalpy-adding Heat Exchanger



#### Advantages and characteristics

- Integrated economizer and liquid receiver, reduces the equipment cost.
- Save device space.
- The heat exchange efficiency at low temperature is significantly improved.

#### Technical data

Model	Heating capacity 1 kw	Heating capacity 2 kw	Cooling capacity kw	Water flow m <sup>3</sup> /h	Height mm
RAK05-CMF-Z	16	12	8.5	2.24	525
RAK06-CMF-Z	18	14	10	2.75	573

**Heating 1:** DB 7 °C, WB 6 °C, Inlet water 40 °C, Outlet water 45 °C

**Heating 2:** DB -12 °C, Outlet water 41 °C

**Cooling:** DB 35 °C, WB 24 °C, Inlet water 12 °C, Outlet water 7 °C

### Double Wall Tube Heat Exchanger



#### Advantages and characteristics

- Use double wall copper tube.
- High safety, anti-leakage and anti-channeling fluid.

#### Technical data

Model	Heating capacity 1 kw	Water flow m <sup>3</sup> /h	Height mm
RAH02-QF	2.5	1.2	251
RAH03-QF	3.5	1.7	291
RAH04-QF	5	2	361
RAH05-QF	9	4	338
RAH06-QF	11	4.4	383

**Heating 1:** DB 20 °C, WB 15 °C, Inlet water 50 °C, Outlet water 55 °C

# Titanium Heat Exchangers

With Concentration And Pursuit Of Perfection. We Design And Manufacture The Best Heat Exchangers



## Titanium Heat Exchanger Introduction

### Product introduction

Being chemically stable titanium exhibits outstanding resistance to corrosion in a wide range of aggressive media. Besides extensive applications in swimming pools, aquariums, breeding farms, electroplating tanks. Marine HVAC and Cooling Solutions for Chemical Process Plants, Innovatively designed titanium heat exchangers by Gimleo are widely used in food, distilled water purified water beer and beverages industries and soilless agricultures etc.

### Feature

- 1 Mould Made outer shells ensure superior capacity of pressure bearing and maximize to 2.1MPa in water side.
- 2 Titanium coils bent by one-step forming technology effectively reduce risk of leakage due to no welding points.
- 3 High quality titanium connectors eliminate any risks of refrigerant leakages.
- 4 All raw materials of Gimleo heat exchangers are strictly compliant with RoHS, CE.
- 5 More than 100 thousand times pressure tests ensure highest quality.

### Material

**The heat transfer tube:** Titanium tube with seam, The grade is TA1.made according to standard GB/T3625-1995. There are 52 bar high pressure test and precise haloger leaking test in the production, make sure they are not leak.

**Shell 1:** High quality PVC, acidproof, alkaiproof, anticorrosion, good resistance to pressure, RoHS performance, environmentally friendly.

**Shell 2:** PP-R has strong resistance to acid and alkali corrosion. The operating temperature is less than 70 degrees Celsius. Shell pressure: 2.1 MPa

Common Version Titanium Heat Exchanger



Advantages and characteristics

- High safety and corrosion resistance.
- Light weight.
- Small water resistance.

Technical data

Model	Heating capacity 1 kw	Water flow m <sup>3</sup> /h	Height mm
MHTA-0.75	2.6	1	465
MHTA-1	3.5	1.5	465
MHTA-1.5	5	2.2	455
MHTA-2	7	3	450
MHTA-3	10.5	4.5	478
MHTA-5	17	7.5	640
MHTA-7	23	10.5	560
MHTA-10	33	15	585
MHTA-12	39	18	615
MHTA-15	47	22.5	695

Heating: DB 24 °C, WB 19°C, Inlet water 26°C, Outlet water 28°C

Titanium Evaporator



Advantages and characteristics

- With pure titanium smooth tube, the cooling capacity is superior.
- High safety and corrosion resistance.
- Light weight.
- Small water resistance.

Technical data

Model	Cooling capacity kw	Water flow m <sup>3</sup> /h	Height mm
ETA-0.5	1.3	0.4	370
ETA-0.75	1.9	0.5	370
ETA-1	2.5	0.7	420
ETA-1.5	3.75	1	530
ETA-2	5	1.5	395
ETA-3	7.5	2	480
ETA-4	10	2.8	580
ETA-5	12.5	3.5	460
ETA-7.5	18.5	5	710

Cooling: DB 35 °C, WB 24°C, Inlet water 12°C, Outlet water 7°C

PPR Titanium Heat Exchanger

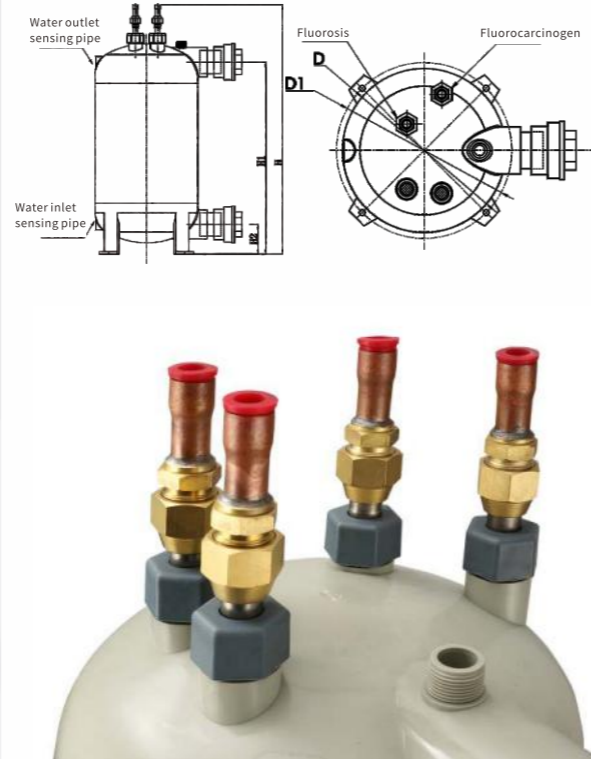

Advantages and characteristics

- Designed for operating temperature up to 70°C.

- Highly resistant to acid and alkali corrosion.

- Capable of operating under extremely high temperature condition.

Technical data

Model	Heating capacity 1 kw	Heating capacity 2 kw	Water flow m <sup>3</sup> /h	Height mm
HTS-1	14	7	3	590
HTS-1.5	17	8.5	3.5	640
HTS-2	21	10.5	4.5	680
HTS-3	28	14	6	812
HTS-5	33	15.5	7	785
HTS-7	35	17	7.5	665
HTS-10	40	20	8.5	665

Heating 1: DB 24 °C, WB 19°C, Inlet water 26°C, Outlet water 28°C

Heating 2: DB 20 °C, WB 15°C, Inlet water 45°C, Outlet water 50°C

Coaxial Heat Exchangers

Innovative & Amazing Products



Titanium tube in titanium tube



Copper tube in copper tube



Titanium tube in PVC tube



Copper tube in steel tube



Titanium thread tube in stainless steel tube



Titanium tube in steel tube

## Coaxial Heat Exchanger Introduction

### Product introduction

The coaxial heat exchanger is composed of concentric inner tubes and outer tubes. The cold and hot fluids flow through the inner tubes and outer tubes in the annular gap while transferring heat. Pressure-resistant and shock-resistant, not easy to deform, dirt-resistant and dirt-resistant, smooth oil return, high safety and good manufacturability, not easy to leak, flexible structure, convenient layout, low price and cost savings. Particularly suitable for heat pump systems. The inner and outer pipes are made of copper, stainless steel etc., which can be widely dispersed in chillers, air-cooled/water-cooled heat pump units, water source/ground source heat pump units, heat recovery units, heat pump water heaters and other refrigeration and air conditioning industries.



### Feature

- Low water quality requirements, larger particles of sediment are not easy to block the water side.
- strong turbulent flow will be formed, and the water side is not easy to scale.
- Heating and cooling capacity performance is relatively balanced.
- Due to its structure, the product has good oil return characteristics.
- The range of use is quite wide, and different heat exchange tubes can be selected according to different application scenarios.

### Material

Copper, stainless steel, titanium, nickel-copper, fully customizable according to your needs.

### Coaxial Heat Exchanger Naming Rules

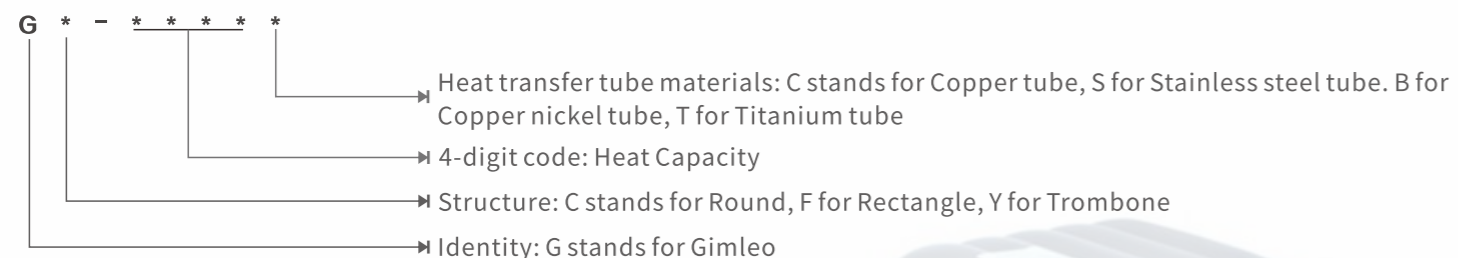

### Technical data

Model	Heating capacity 1 Kw	Water flow m <sup>3</sup> /h	Length mm	Width mm	Height mm
GY-0040C	4	0.7	313	140	140
GY-0060C	6	1	325	140	170
GY-0092C	9.2	1.6	313	140	200
GY-0135C	13.5	2.3	313	140	257
GY-0154C	15.4	2.6	555	245	222
GY-0200C	20	3.4	664	245	222
GY-0228C	22.8	3.9	660	280	262
GY-0400C	40	6.9	690	245	444
GY-0440C	44	7.6	700	280	524

**Heating:** DB 7°C, WB 6°C, Inlet water 40°C, Outlet water 45°C

## Cooperative Services

Keep Excelsior, Professional Service



### Professional Customized Services



Personalized product customization service. According to the customer's installation needs, different multiple heat exchangers are assembled to meet the design requirements of various power models.

The professional technical team designs the drawing to accurately and quickly solve customer needs.



### Customized Procurement Of Heat Pump Accessories

Various heat pump accessories can be customized, and one-stop considerate service can meet your requirements efficiently and quickly.

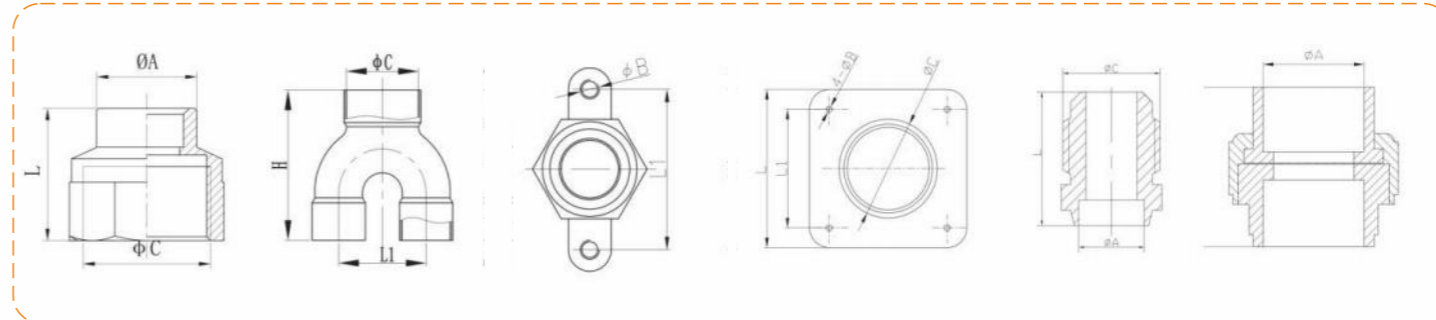
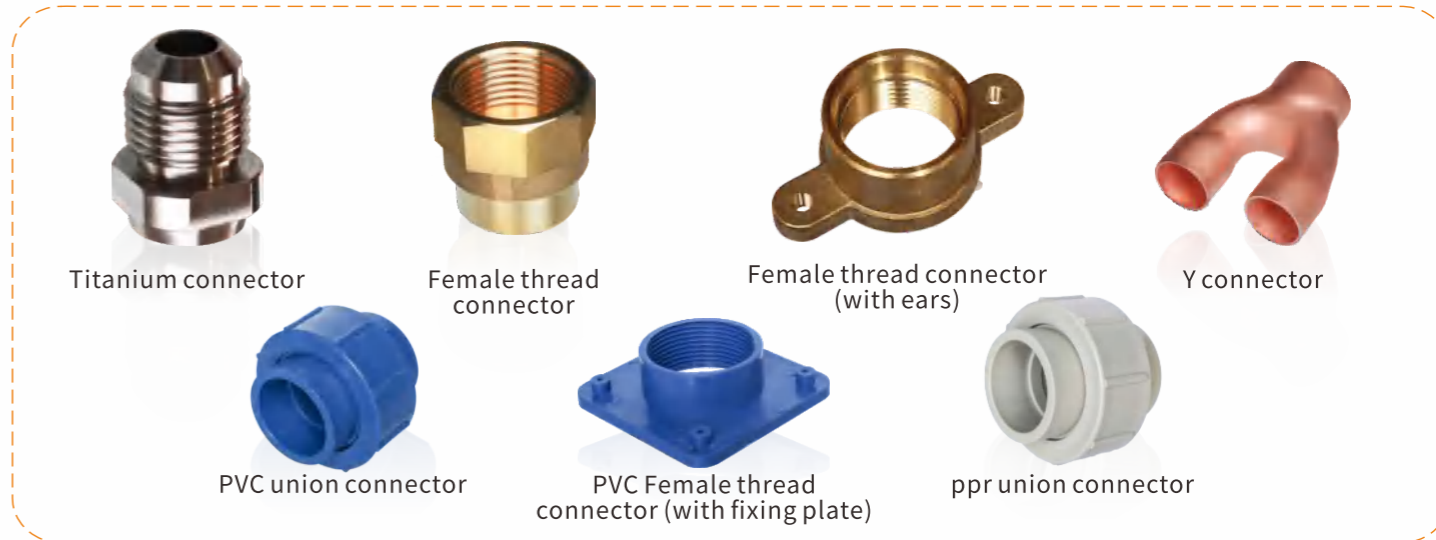

### Technical data

Name	Specification	Thread diameter	Length	Ear distance	Fixed hole size
Female thread connector (with ears)	3/4" * Ø25	3/4	30	50	M6
	1" * Ø25	1"	29.5	55	M6
Female thread connector	3/4" * Ø19.05	3/4"	30	/	/
	1" * Ø19.05	1"	34	/	/
Y connector	2-Φ19.3 × Φ28.7	Φ28.7	60	35	/
	2-Φ16.2 × Φ25.7	Φ25.7	52	29	/
PVC union connector	Φ63	/	95	/	/
	Φ50	/	79	/	/
Titanium connector	Φ12.7 * 3/4"	17/16-14UNF	35	/	/
	Φ19.05 * 3/4"	17/16-14UNF	35	/	/
PVC Female thread connector (with fixing plate)	Φ50	G1.5"	80	60	Φ3